



TOW 288

Powerful & Compact Engine

Water cooled, very fuel efficient and robust engine

Suitable for helicopter and fix-wing installations

Capable to operate at high altitude



www.suter-aviation.ch
www.suter-industries.ch

SUTER INDUSTRIES AG
Head-Quarter

Mr. Lars Jäger
Mettlenstrasse 3
8488 Turbenthal - Switzerland
Phone: +41 52 397 10 60
Mail: info@suter-industries.ch

CAE GmbH
For International

Mr. Dietrich Kehe
Maria Jacobi Gasse 1
1030 Vienna - Austria
Phone: +49 172 900 2619
Mail: info@cae-engines.com

UAV PROPULSION TECH
Representative for USA

Mr. Bob Schmidt
1501 W. Horatio St., #102
33606 Tampa (FL) - USA
Phone: +1(810)441-1457
Mail: bob@uavpropulsiontech.com

Technical Data

Service Ceiling	20'000 ft
Performance	20,0 kW at 6'500 rpm (27,2 HP) 29,2 Nm at 6'500 rpm
Fuel Efficiency	306 g/kWh (BSFC)
Displacement	288 cm ³
Weight	10,0 kg engine 0,5 kg water-pump 2,2 kg exhaust & silencer 1,1 kg 1 kW / 28V starter (SGCU)
Management & Control	ECU / 12V-system Automatic via ECU
Ignition System	CDI (Capacitor Discharge Ignition)
Fuel	Min. 95RON (90AON MOGAS) or AVGAS LL100
Mixture	1:60 (1,6 %) 2-stroke oil API TC

Technical Features

- Two-cylinder, two-stroke boxer engine
- ▶ horizontal & vertical Installation
 - ▶ crankshaft in high strength steel, single piece
 - ▶ connecting rods with needle bearings
 - ▶ Cylinders in casted aluminium, nickel-silicone coated barrel
 - ▶ Throttle control by SERVO & controlled via ECU
 - ▶ ECU for fuel, ignition, cold start, EGT, coolant temperature, altitude compensation & overheat protection
- Options
- ▶ Oil injection
 - ▶ 2 kW / 28 VDC Starter Generator Central Unit (SGCU)
 - ▶ 0.5 kW / 28 VDC Generator Central Unit
 - ▶ Double ignition
 - ▶ Reduction drive

Dimensions

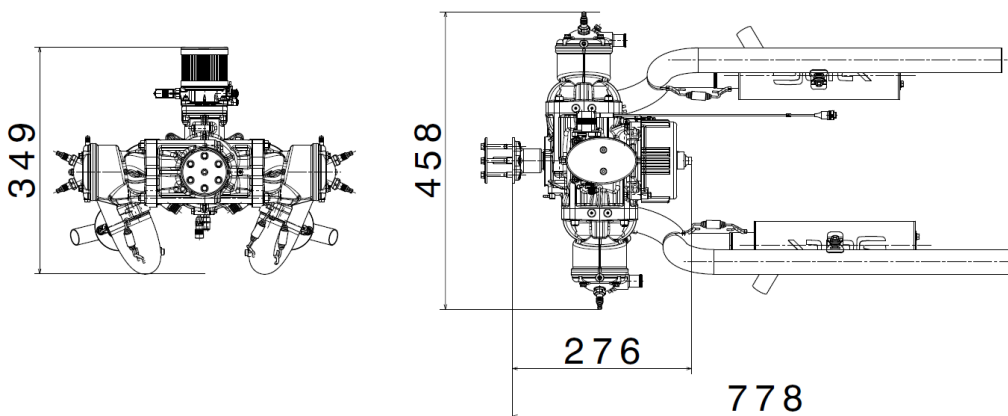

Performance Curve

